

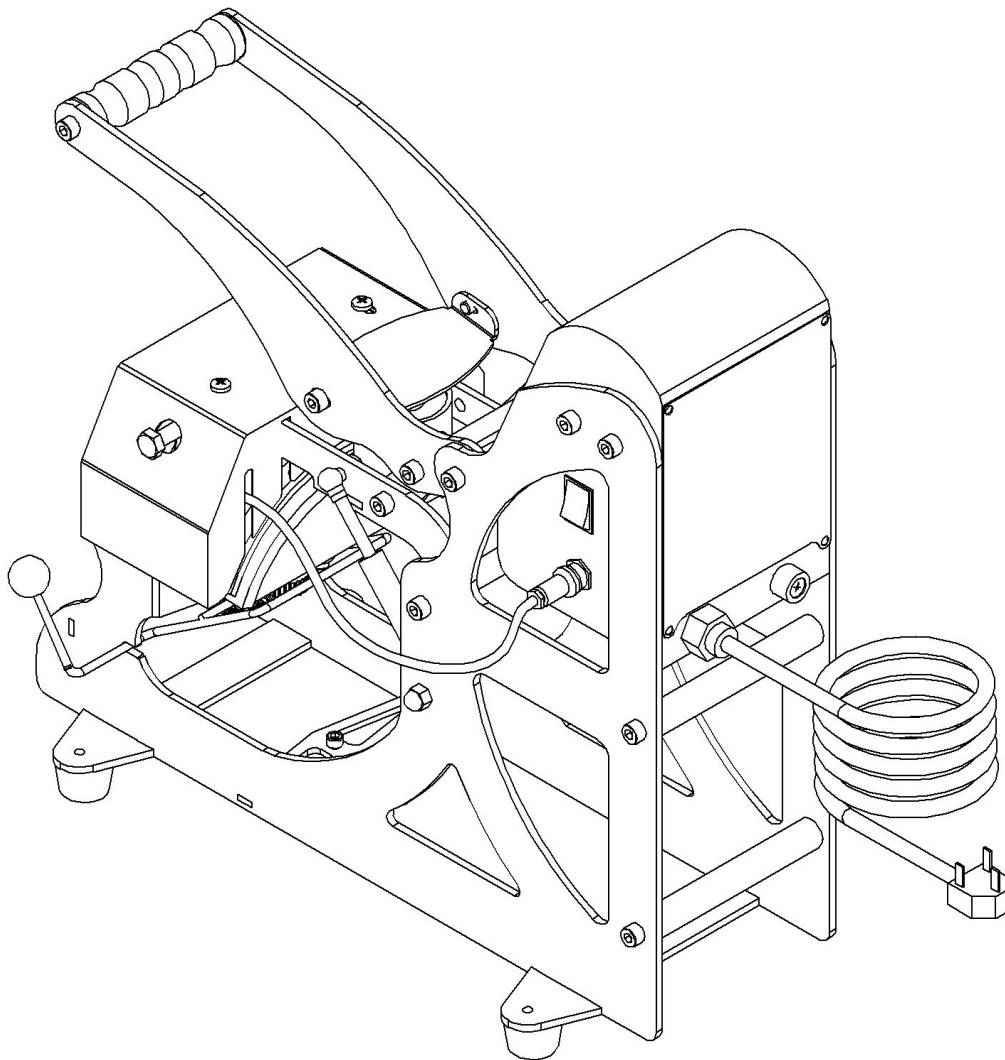

Auto Cap-Pocket Combo Heat Press

Model No.: XP7612



CONTENTS

I. Assembly Drawing -----	2
II. Technical Parameters -----	2
III. Operating Procedure -----	3-5
IV. Changing Heating Elements-----	6
V. Maintenance -----	7
VI. Trouble Shooting for Transfer Print Quality-----	8
VII. Heat Plate Temperature Measurement -----	9
VIII. Electrical Diagram -----	10
IX. Exploded Diagram -----	11
Declaration of Conformity -----	12

I. ASSEMBLY DRAWING

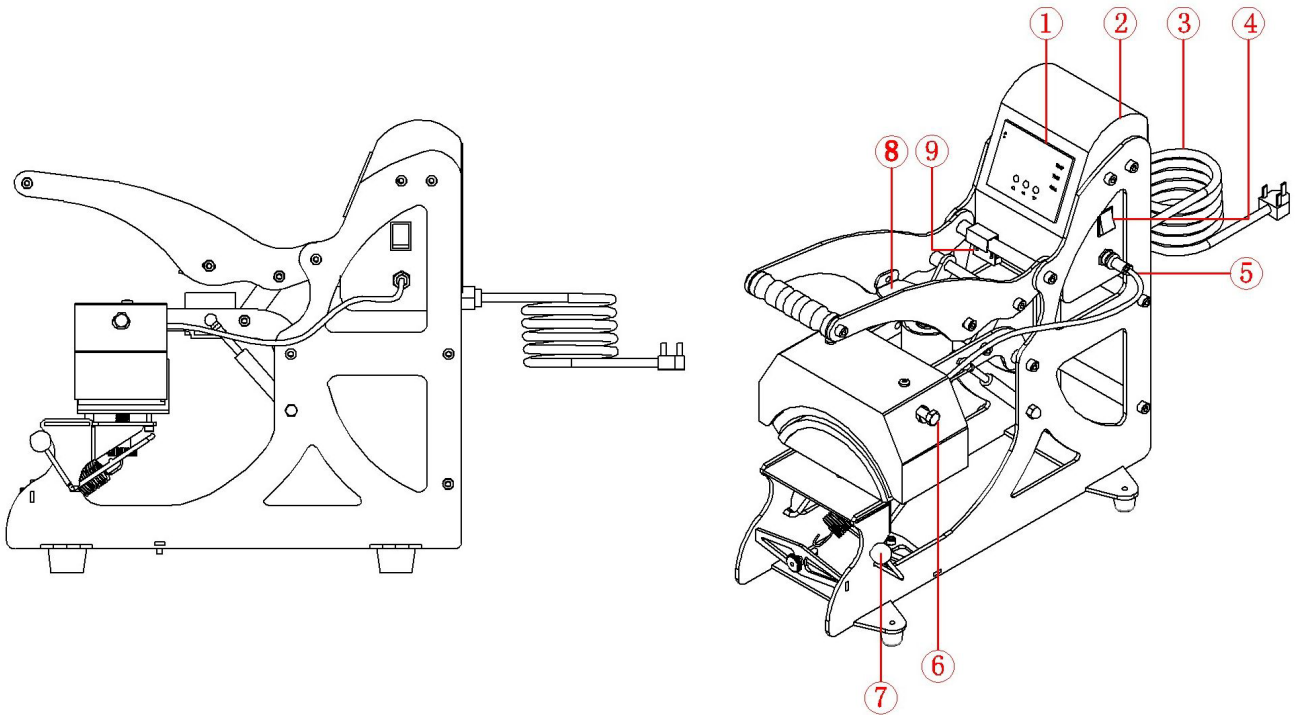

① Digital Controller

② Controller Box

③ Power Cord

④ Power Switch

⑤ Heater Socket

⑥ Connecting Screws

⑦ Cap Attachment

⑧ Electromagnet Plate





⑨ Limit Switch

II. Technical Parameters

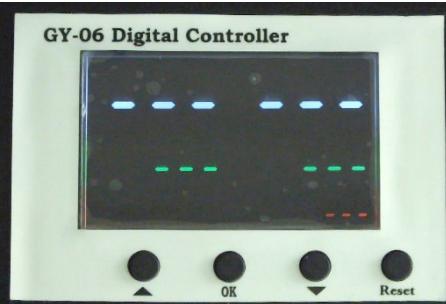

1. **Model No.:** XP7612
2. **Machine Size:** 526 x 500 x 250 mm
3. **Printable Articles Max Size:** 80 x 130 x 10 mm
4. **Voltage:** 220V Single Phase
5. **Power:** 0.6kw
6. **Recommend Setting:** 30~280s; 180~200°C
Time Range: 0~999 Sec
Maximum Temp: 225°C
7. **Packing Size:** 620 x 600 x 350 mm
8. **Gross weight:** 25Kg

III. Operating Procedure

1. Set temperature required



		
<p>Turn on power switch, temperature light is ON. The digital display shows as above.</p>	<p>Press OK button, the  light is on (C denotes Celsius). Press arrows “△” or “▽” to select “°C” or “°F” (F denotes Fahrenheit) according to your habits.</p>	<p>Press OK button, the temp  light is on. Select with arrows the temperature according to different transfer material (Normally 180°C~200°C) SV: Set temperature PV: Current temperature</p>

2. Set time required

	
<p>Press OK button after temperature setting and the time light is on. Select with arrows the time according to different transfer material. SV: Set temperature PV: Current temperature</p>	<p>Press OK button to operating mode. Counter is “transfer cycle”, from 0~999 Sec. Press “Reset” for 5 seconds to return the counter to “0”.</p>

NOTE: Please do as follow:

- 1) When SV and PV has a big difference
- 2) When the temperature shows on the display is not the same as actual temperature on heat platen

	
<p>When SV and PV has a big difference, press OK button for 5 seconds, and press OK button again to adjust the temperature. If SV&PV has difference of 20 degrees, Press arrows “Δ” or “∇” to set to 20.</p>	<p>When the temperature shows on the display is not the same as actual temperature on heat platen, press OK button for 5 seconds to reset mode:</p> <p>① When display shows 200°C, the actual heat platen temperature is 170°C, Press arrows “Δ” or “∇” to set to 30.</p> <p>② When display shows 200°C, the actual heat platen temperature is 230°C, Press arrows “Δ” or “∇” to set to -30</p>

3. Printing methods

Step 1: Make sure the cord is connected well to the wall socket. Place the object (i.e. Cap) on press bed, and transfer paper with images facing down the object, adjust pressure to your requirement, and start the machine.

Step 2: Set the temperature and time required, then temperature starts to rise.

Step 3: When the temperature has risen to the set temperature, the buzzer will sound; then close down heat platen (in the meantime the sound will stop) and the transfer cycle will start.

Step 4: Once the time is up, the upper heat platen will automatically.

Step 5: Consult the Transfer Paper instructions on whether to peel cold or hot. Below are suggested pressing time guidelines for different transfer paper:

- Ink-Jet Transfer Paper (fabric) 14-18 seconds
- Laser Copier/Printer Transfer Paper (fabric) 18-25 seconds
- Sublimation Transfers (onto Fabrics) 25-30 seconds
- Sublimation Transfers (onto FR-Plastic/Woods) 60-70 seconds

5. Recommendations:

1) Ceramic tile transfer: (Mugs & Plates transfer is similar)

Set temperature: 180°C. Set time: 15 seconds

2) T-shirt transfer:

Set temperature: 180°C.

Set time: (chemical fiber use for sublimation transfer paper: 30-50seconds; pure cotton use for T-shirt transfer paper: 10-20 seconds)

step 6: When the temperature has risen to the set temperature, the buzzer will sound; then close down heat platen (meantime the sound will stop) and the transfer cycle will start.

step 7: Time is counting down; once time is up, the buzzer will send out a sound again, the heat platen will open automatically (in the meantime the sound will stop).

Step 8: Work finish and take out the cap. If you want to print on another cap, press  button and confirm the time and temperature set as last time, then repeat above process.

NOTE:

- 1) Please switch off the machine and unplug the power cord when the machine is not in use.
- 2) The heat platen will cool down to the room temperature, if heat press stays un-use for more than 30 minutes.
- 3) The heat-releasing fan will automatically start when the temperature of heat platen reaches 80°C (176°F). It helps to reduce the temperature of electrical parts and prolong the service life of them.
- 4) For better maintenance of heat press, the maximum setting temperature is 210°C (410°F).
- 5) To avoid re-heating the first transfer when printing double sided T-Shirts, insert a sheet of cardboard in between the shirt; adjust the height to less pressure, then press.
- 6) Heat platen may pivot slightly back and forth rotationally. This is due to movement allowance within the clamp assembly, and is normal.

IV. Changing Heating Elements

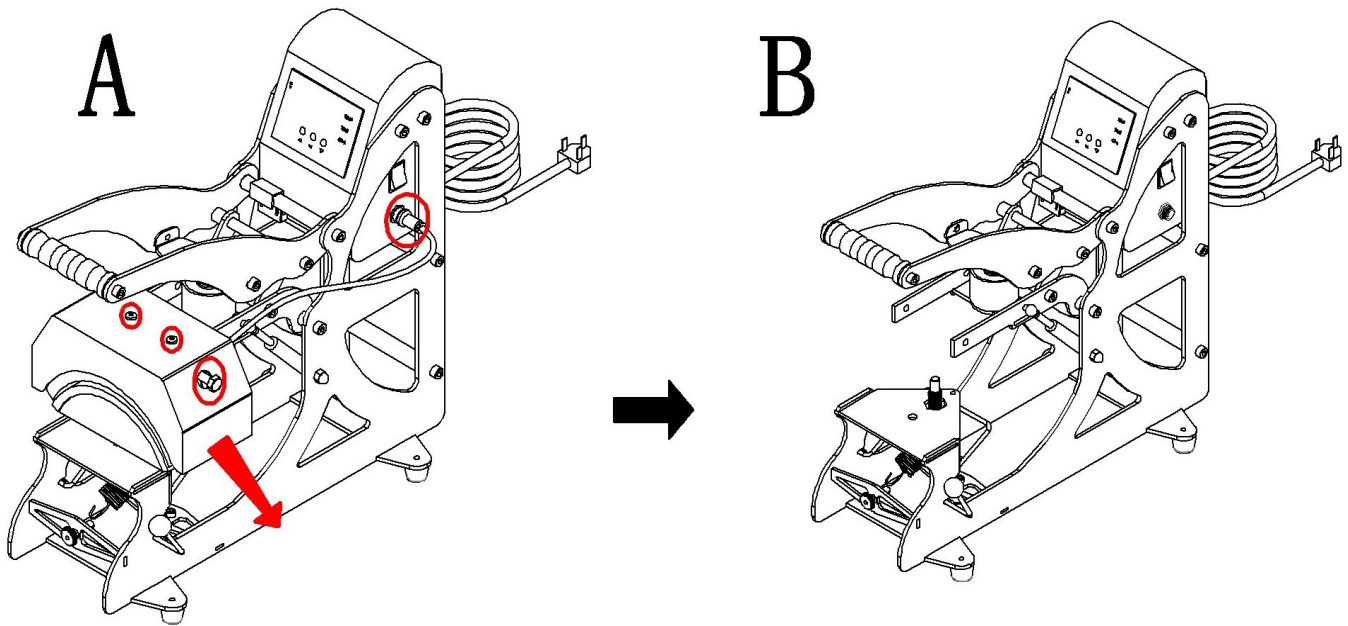

Remove the male socket which is connected to Female socket set in side of electrical case;
Unscrew two screws on the cap heat platen.

Install 15x15cm heat platen as the above picture

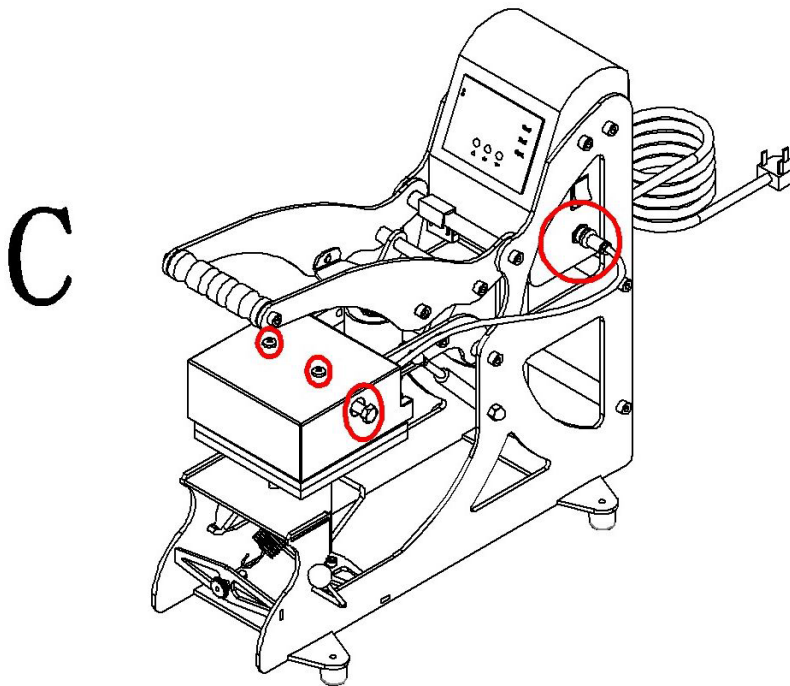

Fitted with locking screws, and insert the socket.

V. Maintenance

1. No action after turn on the machine

- 1). Check the plug whether it connects well or whether it is broken.
- 2). Check the power switch or digital controller whether it is broken.
- 3). Check the fuse whether it has been burnt out.
- 4). Indicating light is on, but no display on screen, check the 5 cable of Railway transformer. If it's loosening, showing the problem is poor connection. If they connect well, showing that the Transformer is faulty.

2. The display screen are working well, but no temperature increasing on the heat platen.

- 1). Check whether the thermocouple of the heat platen touches well. If the thermocouple is loose, the display will show 255 and machine keeps beeping.
- 2). Check if the indicating light of solid-state relay is on, if not, check if the relay or digital controller is broken.
- 3). If you already changed the new solid-state relay but the heat platen still can't heat up, check if the heat platen is faulty or the heat platen's power cable is loose, need to change by new heat platen.

3. The heat platen works well, but suddenly the display screen shows 255°C.

- 1). Check whether the thermocouple of the heat platen touches well.
- 2). If the thermocouple touches well but still show 255°C, then it is faulty.

4. The machine is heating during 0~180°C, but display number jumps to above 200°C or 300°C suddenly, or the number on display jumps irregularly.

- 1). Check whether the thermocouple of the heat platen touches well.
- 2). If the thermocouple is good, It shows that the program of digital controller is broken, which namely IC or is broken, need to change by new controller.

5. The temperature is out of control: Set 180°C, but the actual temperature is above 200°C.

- 1). It means the solid-state relay is broken, out of control, need to change the relay.
- 2). Or the digital controller is faulty and it keeps conveying electric to relay, need to change controller.

6. The setting temp and time becomes abnormal after exchange the heat platen

- 1). Please reset the temp and time according to the operation process manual.

7. Other notice

- 1). In order to prolong the machine service life, please add the lubrication oil regularly on the joints.
- 2). In order to keep the heat platen's good transfer effect, you need to protect the heat platen carefully whenever you are using it or not.
- 3). Please keep the machine in dry place.
- 4). If you are not able to solve the electrical parts problem, please kindly contact the supplier and get technical support.

8. The following checks should be carried out at regular intervals by a qualified and competent person:-

- Electrical connections
- Mechanical moving parts

VI. Trouble shooting for transfer print quality

1. If the colour is not as bright as photo after printing.

Solution(s):

- a. Adding transfer time
- b. Increasing transfer temperature

2. If the print colour is too brown or the transfer paper is almost burnt.

Solution: Reduce the setting temperature

3. If the print is blurring.

Solution: Reduce the transfer time

4. If print colour is different/partial transfer effect is not good enough.

- a. The pressure is not correct (use more pressure).
- b. The job has not been pressed for long enough.
- c. The transfer paper is of a poor quality.

5. Transfer paper sticks to the object after transfer cycle.

- a. The temperature is too high.
- b. The ink quality is poor.

6. Prolonging your machines useable life.

Add lubrication oil regularly.

7. Ensuring heat transfer quality.

Take care of your press by storing carefully when not in use.

8. Site the machine in a dry place and on a firm and stable surface.

9. Always use quality replacement parts fitted by a competent person.

10. If your press will not work please contact <https://www.heatpressesdirect.co.uk/>

VII. Heat Plate Temperature Measurement

Testing of the Heat Plate for temperature consistency or fault condition should only be undertaken after consulting a qualified engineer, and then only using a wired Digital Thermometer (***please see note below**).



***Please Note:**

The Digital Thermometer with external probe is suitable for surface, air and immersion/penetration measurement, which is required for all Heat Presses Direct heat presses.

Laser Thermometers only measure air surfaces which can be misleading due to currents of hot air floating on the surface of the heat plate.

VIII. Electrical Diagram

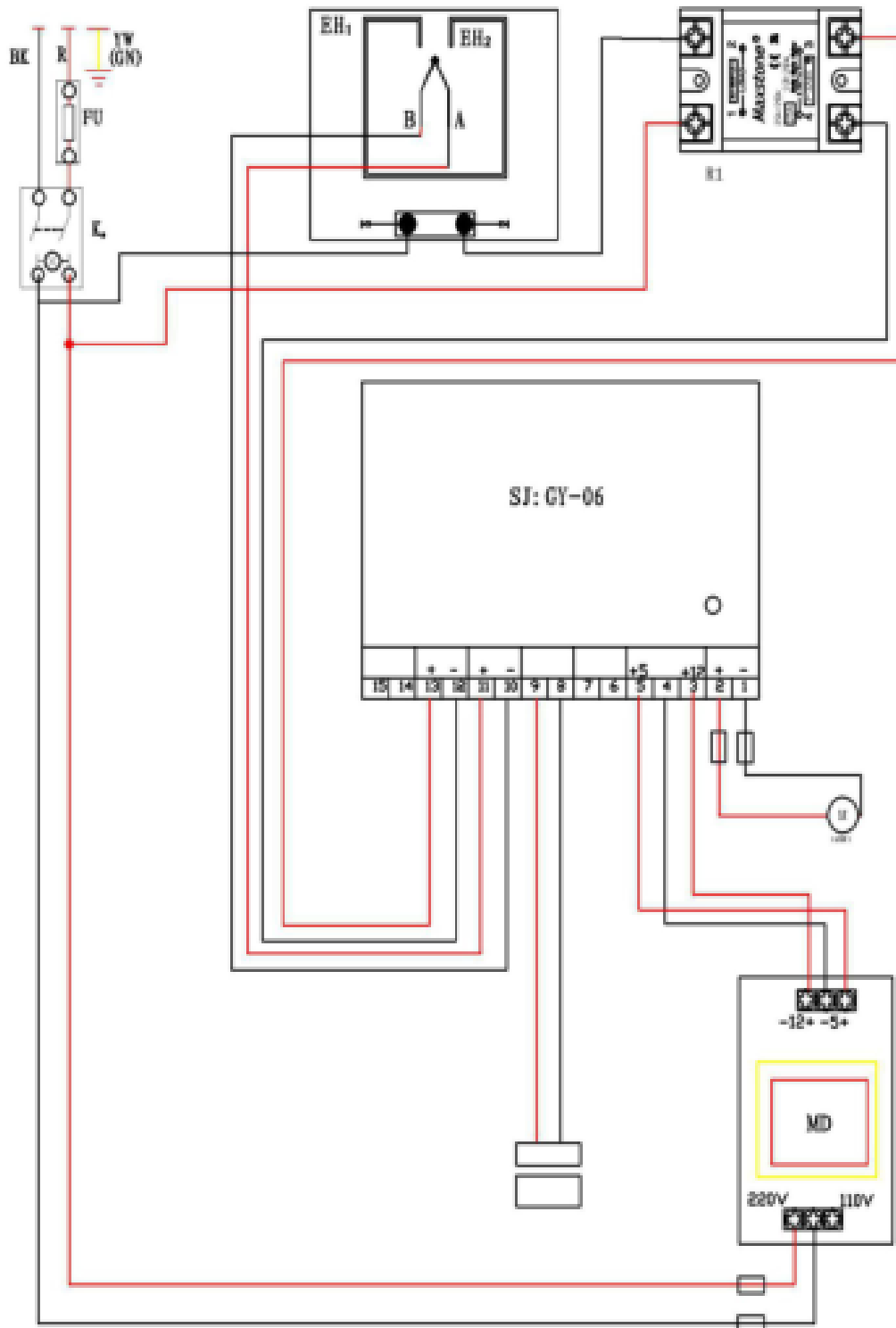

K₀:Power Switch

T:Transformer

EH1 EH2:Heating Pipe

C:Magnet

FU:Fuse

MD:Magnet Driver

K₂:Limit Switch

R1:Relay

SJ:Digital Controller

IX. Exploded Diagram

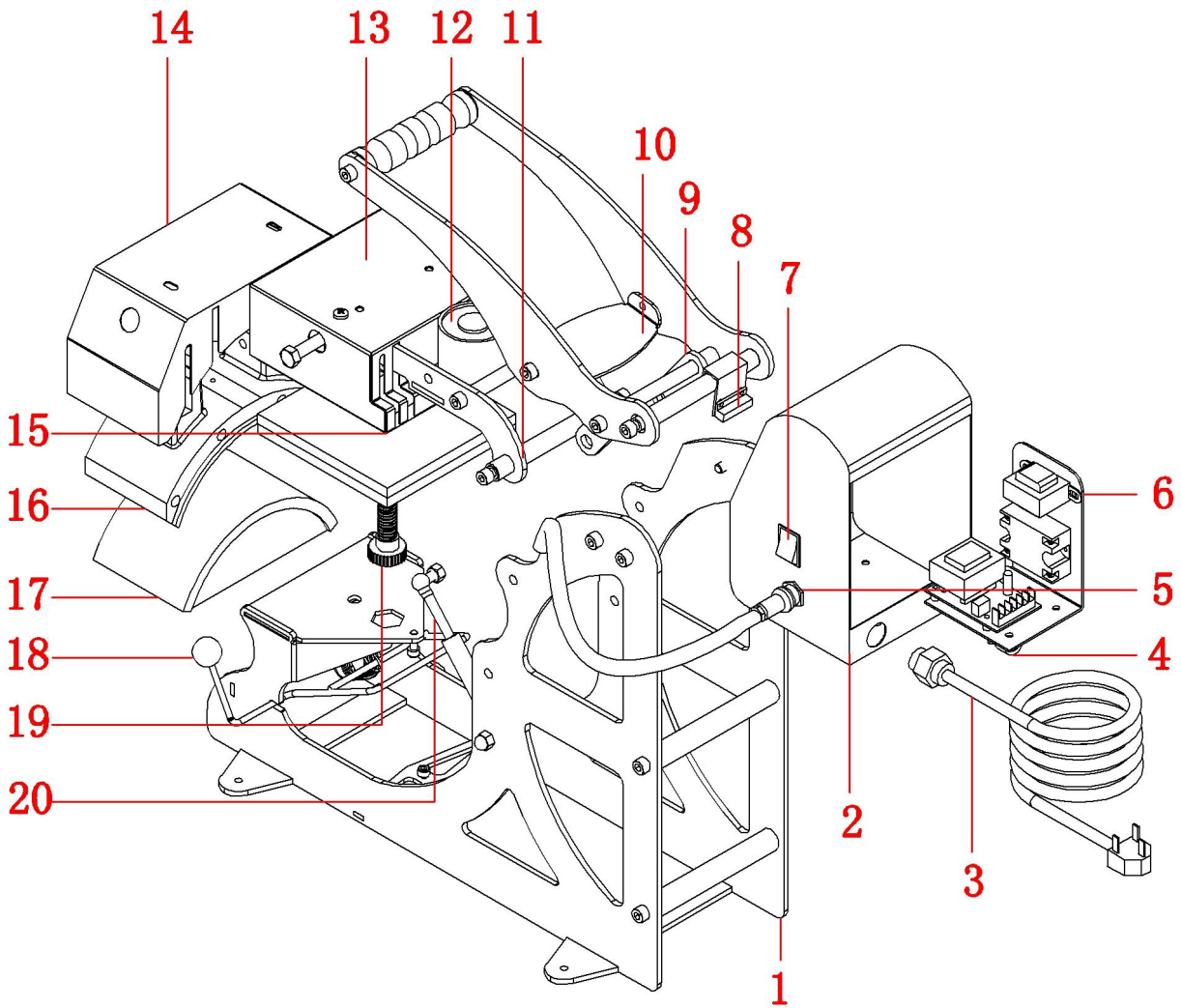



No.	Part Name	Qty
1	Machine Frame	1
2	Electric Case	1
3	Power Cord	1
4	Fuse Holder	1
5	Heating Plate Socket	1
6	Electrical Parts Bracket	1
7	Power Switch	1
8	Limit Switch	1
9	Connecting Piece	2
10	Electromagnet Suck Plate	1
11	Davit Arm	1
12	Electromagnet	1
13	Flat Heat Platen Cover	1
14	Cap Heater Cover	1
15	Flat Heat Platen	1
16	Cap Heater	1
17	Electromagnet	1
18	Hat Rack	1
19	Pressure Adjust Gear	1
20	Gas Spring	1



Charterhouse Holdings PLC

DECLARATION OF CONFORMITY

Application of Council Directives:	European Low Voltage Directive (LVD), European Machinery Directive (MD), Electro Magnetic Conformity (EMC)
Standards to which Conformity is Declared:	(LVD): <u>EN 60204-1:2018</u> (MD): <u>EN ISO 12100:2010 2006/42/EC Annex1</u> (EMC): <u>EN 61000-6-2:2019</u>
Manufacturer's Name:	Charterhouse Holdings PLC
Manufacturer's Address:	Oakridge Park, Trent Lane, Castle Donington, Derby DE74 2PY United Kingdom
Type of Equipment:	Auto Cap-Pocket Combo Heat Press
Standards Compliance:	 
Model Number:	XP7612
Serial Number:
Year of Manufacture:

I, the undersigned, hereby declare that the equipment specified above conforms to the above directives and standards.

Place: Castle Donington, United Kingdom

Signature: ..  ..

Date: 15th June 2023

Full Name: Miles Carter
Position: Chief Executive